

# SCHWENKBEREICH

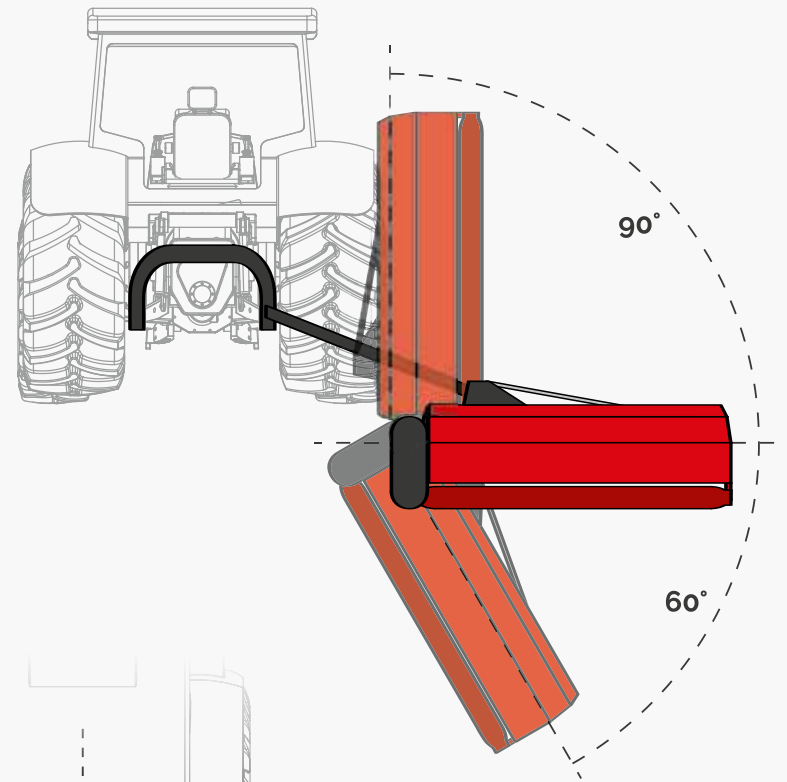

Die Serie COBRA hat mit 1400 mm einen extrem weiten Seitenverschub in Fahrtrichtung rechts.

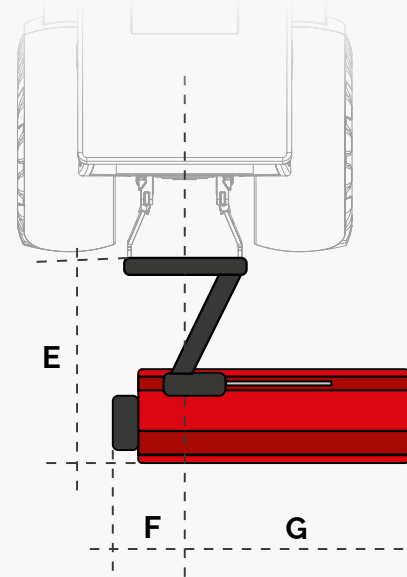
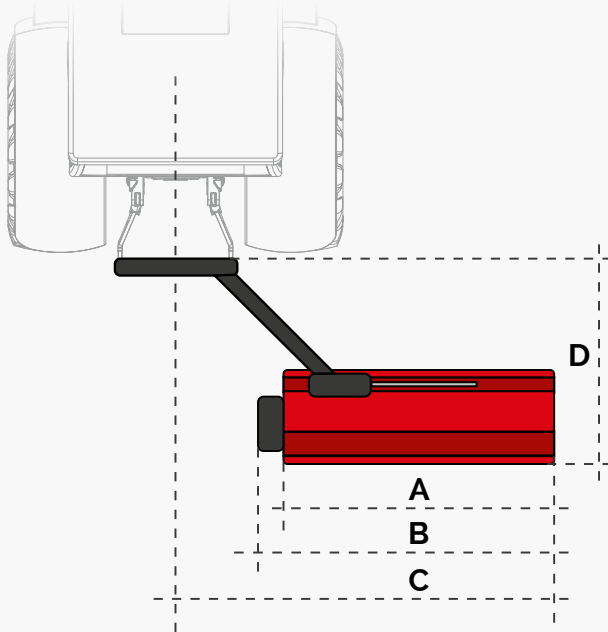

Typ	A	B*	C*	D*	E	F*	G*
ROAD L 100	1000	1330	1780	1660	1560	650	680
ROAD L 130	1300	1630	2080	1660	1560	650	980
ROAD L 160	1600	1930	2380	1660	1560	650	1280
ROAD MTL 100	1000	1330	1780	1720	1620	650	690
ROAD MTL 120	1200	1530	1980	1720	1620	650	890
ROAD MTL 140	1400	1730	2180	1720	1620	650	1090
ROAD MTL 160	1600	1930	2380	1720	1620	650	1290
ROAD VL 120	1200	1600	2120	2050	1780	1120	480
ROAD VL 140	1400	1800	2320	2050	1780	1120	680
ROAD VL 160	1600	2000	2520	2050	1780	1120	880
ROAD VL 175	1750	2150	2670	2050	1780	1120	1030
ROAD VL 200	2000	2400	2920	2130	1880	1120	1280
ROAD VL 240	2400	2800	3320	2130	1880	1120	1680
ROAD V 140	1400	1800	2320	2050	1780	1120	680
ROAD V 160	1600	2000	2520	2050	1780	1120	880
ROAD V 175	1750	2150	2670	2050	1780	1120	1030
ROAD V 200	2000	2400	2920	2130	1880	1120	1280
ROAD V 220	2200	2600	3120	2130	1880	1120	1480
ROAD V 240	2400	2950	3320	2178	1880	1270	1680
ROAD V 260	2600	3100	3460	2230	2080	1300	1860
COBRA V 160	1600	2020	3000	2300	2200	420	1600
COBRA V 175	1750	2170	3150	2300	2200	420	1750
COBRA V 200	2000	2420	3400	2300	2200	420	2000
COBRA V 220	2200	2620	3600	2300	2200	420	2200
COBRA V 240	2400	2820	3800	2300	2200	420	2400
COBRA FS 150	1.500	1.950	3.040	2.490	2685	495	1.455
COBRA FS 175	1.750	2.200	3.290	2.490	2685	495	1.705
COBRA FS 200	2.000	2.450	3.540	2.490	2685	495	1.955
COBRA FS 225	2.250	2.700	3.790	2.490	2685	495	2.205
COBRA FS 250	2.500	2.950	4.040	2.490	2685	495	2.455
EXTREME 175	1.750	-	4.070	1.560	1.870	860	3.150
EXTREME 200	2.000	-	4.320	1.560	1.870	860	3.400
EXTREME 220	2.200	-	4.520	1.560	1.870	860	3.600
EXTREME 240	2.400	-	4.720	1.560	1.870	860	3.800

\* Die Maße beziehen sich auf ein außenliegendes Getriebe.