

SCHWENKBEREICH

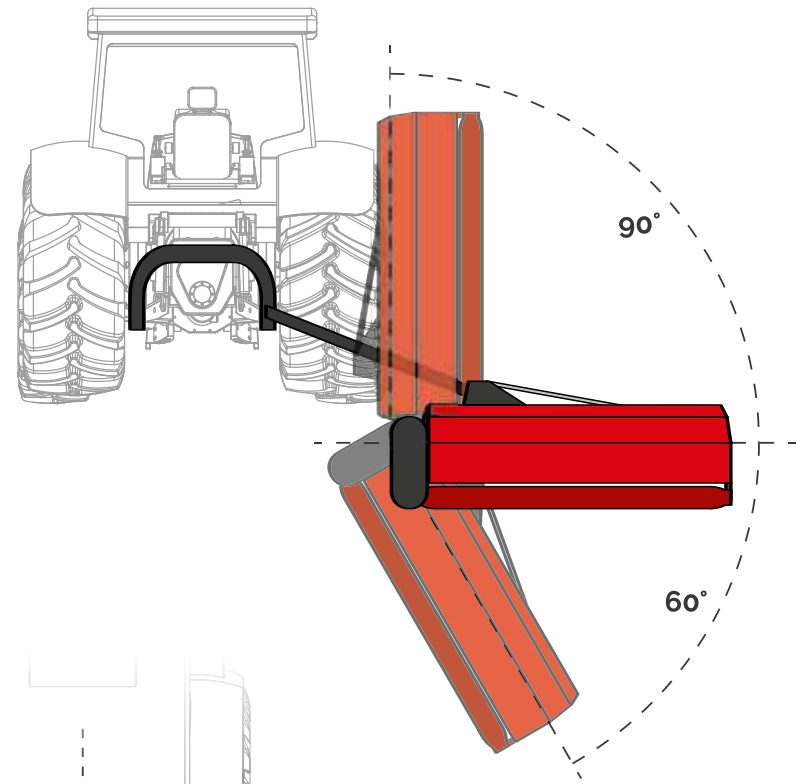

Die Serie COBRA hat mit 1400 mm einen extrem weiten Seitenverschub in Fahrtrichtung rechts.

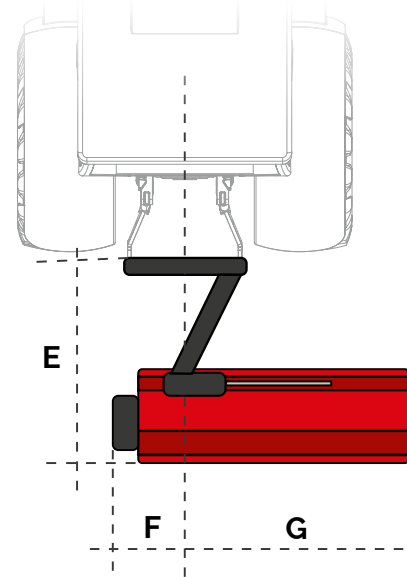
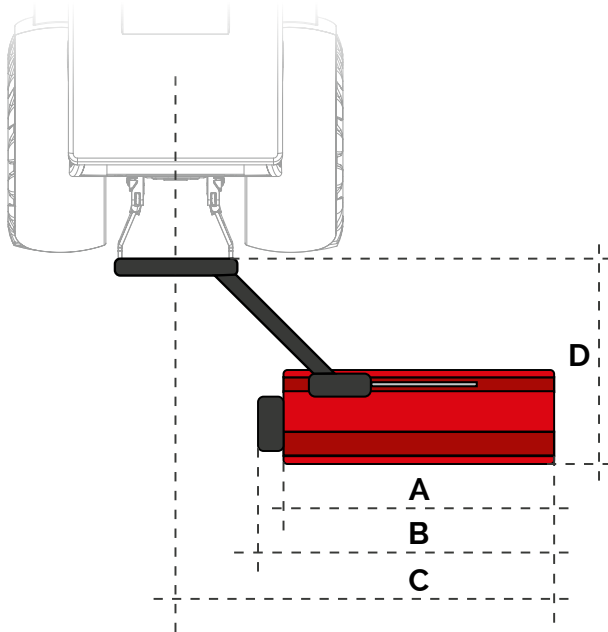

Typ	A	B*	C*	D*	E	F*	G*
ROAD L 100	1000	1330	1800	1660	1560	680	650
ROAD L 130	1300	1630	2100	1660	1560	680	950
ROAD L 160	1600	1930	2400	1660	1560	680	1250
ROAD MTL 100	1000	1330	1800	1720	1620	680	650
ROAD MTL 120	1200	1530	2000	1720	1620	680	850
ROAD MTL 140	1400	1730	2200	1720	1620	680	1050
ROAD MTL 160	1600	1930	2400	1720	1620	680	1250
ROAD VL 120	1200	1620	2200	1990	1890	1090	530
ROAD VL 140	1400	1820	2400	1990	1890	1090	730
ROAD VL 160	1600	2020	2600	1990	1890	1090	930
ROAD VL 175	1750	2170	2750	1990	1890	1090	1080
ROAD VL 200	2000	2420	3000	2050	1890	1090	1330
ROAD V 140	1400	1820	2400	2050	1940	1090	730
ROAD V 160	1600	2020	2600	2050	1940	1090	930
ROAD V 175	1750	2170	2750	2050	1940	1090	1080
ROAD V 200	2000	2420	3000	2050	1940	1090	1330
ROAD V 220	2200	2620	3200	2050	1940	1090	1530
ROAD V 240	2400	2820	3400	2050	1940	1090	1730
ROAD V 260	2600	3020	3600	2130	2080	1090	1930
COBRA V 160	1600	2020	3000	2300	2200	420	1600
COBRA V 175	1750	2170	3150	2300	2200	420	1750
COBRA V 200	2000	2420	3400	2300	2200	420	2000
COBRA V 220	2200	2620	3600	2300	2200	420	2200
COBRA V 240	2400	2820	3800	2300	2200	420	2400
COBRA FS 150	1.500	1.950	3.040	2.490	2685	495	1.455
COBRA FS 175	1.750	2.200	3.290	2.490	2685	495	1.705
COBRA FS 200	2.000	2.450	3.540	2.490	2685	495	1.955
COBRA FS 225	2.250	2.700	3.790	2.490	2685	495	2.205
COBRA FS 250	2.500	2.950	4.040	2.490	2685	495	2.455
EXTREME 175	1.750	-	4.070	1.560	1.870	860	3.150
EXTREME 200	2.000	-	4.320	1.560	1.870	860	3.400
EXTREME 220	2.200	-	4.520	1.560	1.870	860	3.600
EXTREME 240	2.400	-	4.720	1.560	1.870	860	3.800

* Die Maße beziehen sich auf ein außenliegendes Getriebe.